

# Weighing & Dosing



## **XPE Weighing Solutions**

Fast and reliable results

Easy compliance

Sustainable investment

## **Reliable Results for Years to Come**

## Follow the Green Light

**METTLER TOLEDO**

# Reliable Results

## Begin with Accurate Weighing

**Achieving reliable analytical results is dependent on the accuracy of the initial sample. Any error in sample preparation will be simply perpetuated, or even magnified, in downstream processing. With up to 60% of laboratory time spent preparing samples, you need weighing solutions that ensure you get accurate results first time to avoid out-of-specification errors and costly reworking.**

Whether you want to weigh several kilograms or just a few milligrams, XPE weighing and dosing solutions offer you outstanding weighing performance and innovative technologies to help make your daily tasks easier, error-free and compliant.

### XPE Weighing and Dosing Solutions – delivering reliable results

#### Electrostatic issues addressed



To overcome this major challenge in analytical weighing, StaticDetect™ technology detects electrostatic charge on the sample and/or its container. The weighing error is measured and a warning is given if the user-defined limit is exceeded. Antistatic measures can then be employed.

#### Fast and stable performance



The innovative new SmartPan™ precision balance weighing pan makes it possible to weigh to 5 mg readability without a draft shield, delivering results up to two times faster, even in a fume cupboard. Repeatability values are improved up to two-fold.

#### Consistently accurate dosing



To achieve the highest level of safety and accuracy in handling and preparing samples, balances can be upgraded with Quantos automated powder and liquid dispensing modules. Gravimetric sample preparation eliminates variability and errors, and complies with USP 841.



### Data integrity



LabX automatically saves all results and process information securely in a central database. This ensures full traceability and assists with FDA 21 CFR Part 11 compliance. There is no longer any need to document results manually and therefore transcription errors are completely eliminated.

### Reliable Results for Years to Come

Follow the Green Light

# Follow the Green Light For Compliant Results

**XPE sets a new benchmark for performance, reliability and compliance in laboratory weighing. Intelligent features and innovative technologies combine to ensure ease of use as well as deliver results you can trust.**

The innovative built-in StatusLight™ at the front of the balance terminal lets you see at a glance if you have the green light for weighing: balance calibration and routine tests are up to date, the balance is level, and functional tests are satisfied – simply follow the green light!



The know-one-know-all terminal makes it easy to change between using different balances as well as other METTLER TOLEDO analytical instruments.

## Balances

Weighing pan  
Max capacity  
Readability

### XPE Precision

Large  
10 – 64 kg  
0.01 g – 0.01 g

The best possible weighing performance for high capacity loads.

▶ **High capacity weighing**

### XPE Precision

Small (includes SmartPan)  
1.2 kg – 10 kg  
0.01 g – 0.5 g

High stability with SmartPan for loads up to 10 kg.

▶ **Extraordinarily stable**

### XPE Precision

Small  
200 g – 5 kg  
0.1 mg – 1 mg

Integrated draft shield for accurate weighing up to 6 kg.

▶ **Small sample weighing**



- Chapter With XPE:**
- <41> Smallest net weight
  - <841> Volumetric and/or gravimetric sample preparation
  - <1058> Validation and qualification (optional services)
  - <1251> Built-in routine testing tools - services and support also available



**XPE Analytical**

SmartGrid™

100 g – 500 g

0.1 – 0.005 mg

Outstanding performance supporting high process security.

▶ **Secure analytical weighing**

**XPE Micro-analytical**

SmartGrid micro

20 g – 50 g

1 µg – 2 µg

Unique 50 g capacity – weigh directly into tare vessels.

▶ **Very small samples**

**Quantos automated dosing**

50 g – 200 g

1 mg – 1 µg

Automated powder and liquid dosing with smallest minimum weights.

▶ **Highest accuracy and safety**

# Meeting Your Needs Today – and Tomorrow

**An investment in an XPE balance ensures you get the accurate weighing results you want today. To protect your investment, these flexible balances enable you to adapt your balance over time through the addition of accessories, extra peripheral devices, LabX and even Quantos dosing modules. Be ready for today as well as prepared for the years to come.**

- Automated powder and liquid dosing – Quantos
- Data management and process security – LabX
- Efficient applications – accessories and peripheral devices

## Upgrade your XPE balance

This example shows how you can upgrade your XPE balance over time with useful accessories, firmware, LabX or Quantos automated powder and liquid dosing modules and auto sampler.



XPE206DR analytical balance



Quantos liquid dosing module



Quantos liquid and powder dosing modules



Quantos powder dosing module with auto sampler

**Instrument upgrade**

High-end automated solutions for preparing highly accurate solutions using valuable substances.

**LabX Laboratory Software**

SOP user guidance on the instrument, automatic data handling, bidirectional integration with ERP systems.



**Useful accessories**

Optimize processes with e.g. ErgoClip container holders and convenient stand, MinWeigh Door with dosing window



- Selection of non-critical materials
- PVC-free, mercury-free
- Energy efficient manufacturing and logistics

# Pioneering Innovations Deliver Results You Can Trust

**With so many laboratory analyses beginning with sample preparation on the balance, obtaining reliable weighing results is absolutely essential.**

Thanks to METTLER TOLEDO's extensive weighing competence and years of expertise in manufacturing laboratory instruments, XPE weighing and dosing solutions incorporate a multitude of pioneering technologies so that you can rely on accurate and repeatable results.

## Electrostatic detection



StaticDetect checks for electrostatic charge on the sample and/or its container. Weighing error is measured and a warning is given if the user-defined limit is exceeded. Antistatic measures can then be employed.

## Unique weighing grid



SmartGrid minimizes air turbulence in the weighing chamber for fast and stable results and avoids weighing error from spilled substances. SmartGrid, the tray underneath and the complete draftshield are easily cleaned in the dishwasher.

## Automated dosing



Quantos safely dispenses free-flowing, toxic, and even hard-to-handle static powders accurately and directly into target vessels. Minimum sample weight can be reduced by up to 30%.





### Wind defying weighing pan



SmartPan minimizes the effects of air currents on the weighing cell to dramatically improve accuracy and stabilization times. Spillages remain inside the pan base for safe disposal and cleaning.

### RFID solutions



Smart Tag RFID labels on titration beakers allow information transfer from the balance to your METTLER TOLEDO Titration Autosampler. EasyScan™ also checks testing and calibration dates on RFID tagged pipettes (routine pipette testing application included).

### LabX for process security

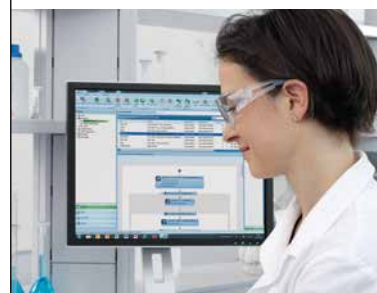

By implementing your SOP workflows in LabX you can be sure that users always follow the correct procedures. All data and process information is saved securely in a central database providing full traceability and assisting in compliance with FDA 21 CFR Part 11.

# XPE Micro-analytical Balances

## Very Small Samples

**Are your samples very valuable? Are they only available in small quantities or effective in just the tiniest of doses? Or perhaps you want to weigh with a larger tare container? XPE micro-analytical balances display unsurpassed accuracy even with the smallest of samples.**

The XPE56 micro-analytical balance has a unique maximum capacity of 52 g with a readability of 1  $\mu\text{g}$ , providing a resolution of over 50 million digits. Highly sensitive, and yet robust, the XPE56 is perfect for weighing the smallest samples directly into larger tare containers.

### Fast results



XPE are the only micro-analytical balances in the world with a hanging weighing pan. With minimal air turbulence in the weighing chamber, stabilization time is reduced and results are faster. Particularly beneficial when used in a fume cupboard or safety cabinet.

### Save valuable samples



With 52 g capacity on the XPE56, you can weigh directly into larger tare containers and avoid the typical sample loss when transferring from weighing paper. And with a minimum weight of just 1.4 mg, you can use just the smallest quantities of your valuable samples.

### Thermal stability



Thermoelectric cooling using a Peltier element ensures the internal temperature of the balance remains steady to provide accurate results. This robust technology is extremely durable and ensures best weighing cell performance for years to come.



### Flexible access with dual motorized doors

XPE micro-analytical balances have motorized doors on both the outer and the smaller inner draft shields. It's easy to set up one SmartSens sensor to open both sets of doors for when you want to place your tare container on the balance – just wave your hand over it to activate. To keep air disturbance to a minimum for dosing, the other sensor can be used to open just the outer door. Left and right dosing possible.



Printouts fade-proof

up to **25** years

### Flexible printing and labeling

The P-56 and P-58 universal thermal printers offer fast and error-free results documentation as well as label printing with barcodes.

# XPE Analytical Balances

## Secure Analytical Weighing

**XPE analytical balances provide outstanding performance in analytical weighing and support the highest requirements for security, efficiency and ease of compliance.**

Automatic electrostatic detection combats one of the biggest challenges in analytical weighing – weighing errors caused by electrostatic influences. Innovative features, such as SmartGrid and StatusLight plus RFID capabilities combine to give you absolutely reliable results. Connecting your balance to LabX provides full data security to easily meet the strictest regulations.

### Secure weighing



The SmartTrac weighing-in guide ensures you dose within tolerance. StatusLight shows green so you can rest assured that all routine tests are up to date. StaticDetect provides you with a warning if static charges are detected. You get results you can trust!

### Safe routine operation



For safe cleaning, the draft shield, SmartGrid and drip tray are dismantled in seconds and all parts are dishwasher proof. When working with hazardous samples, disposable terminal covers provide additional protection for users and help avoid cross-contamination.

### Seamless integration



Connect your balance to LabX for seamless integration with your existing information systems e.g. ELNs and LIMS. Manual transcription is no longer needed since all data is saved securely, easily accessed for report generation or further data analysis.



### **ErgoClip container holders**

Weighing directly into the tare container eliminates transfer errors and saves money by minimizing sample loss. Even unusual shaped containers are held securely in place. In combination with the MinWeigh Door™ accessory, ErgoClips help you achieve the lowest possible minimum weight. Left and right dosing possible.

# Solving the Electrostatic Challenge

## Detection and Elimination

**Electrostatic charge is one of the major challenges faced in analytical weighing. Through normal handling, containers and samples can easily become charged, leading to weighing errors. The charge may also cause particles from powdered samples to be scattered, creating additional problems when handling valuable or toxic substances.**

XPE micro-analytical and analytical balances are the only balances in the world with revolutionary technology which analyzes the weighing signal to determine the weighing error caused by electrostatic charge. If this error exceeds the user defined limit, the blue StaticDetect light is illuminated. Antistatic measures can then be employed: the point electrode, which attaches to the side of the balance, or freestanding antistatic devices are also available.

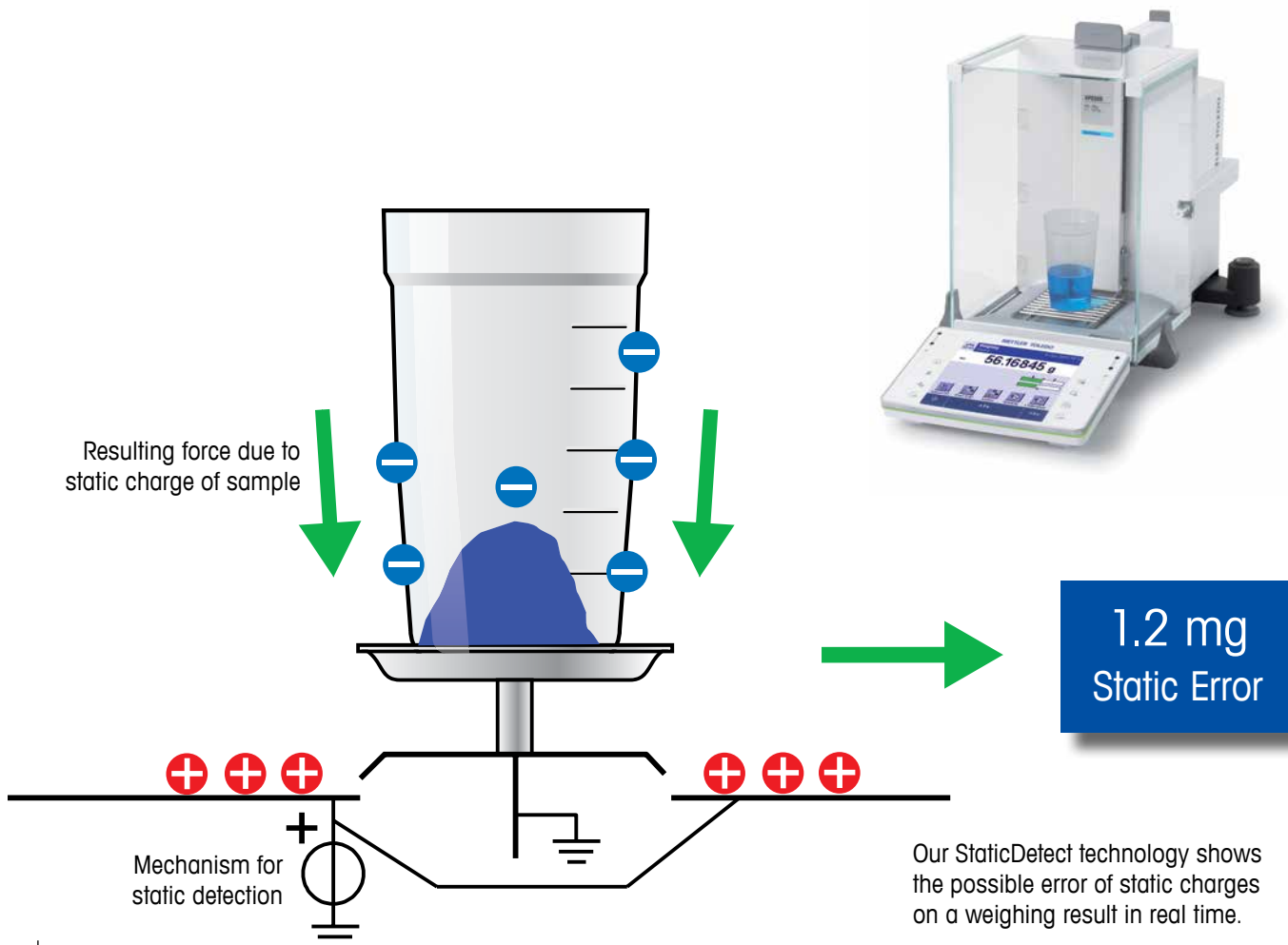

DeltaRange®

Max 81g/220g

d = 0.01mg/0.1mg

StaticDetect



**Trusted results**

"Now I know I can trust my results. My XPE lets me know immediately if I have an issue with electrostatic charges."

Try our self-diagnosis test on your own balance and download the white paper:

► [www.mt.com/xpe-analytical](http://www.mt.com/xpe-analytical)

# Technical Specifications

## Micro-analytical and Analytical Balances

### XPE Micro-analytical Readability 1 µg – 2 µg

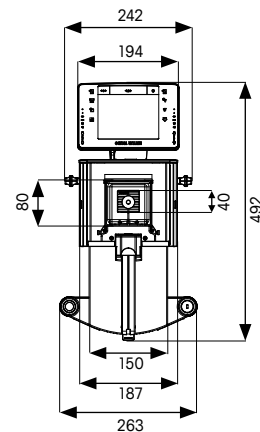
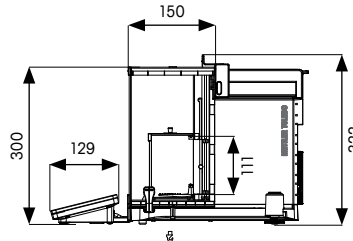

### XPE Analytical Readability 0.1 mg – 0.005 mg

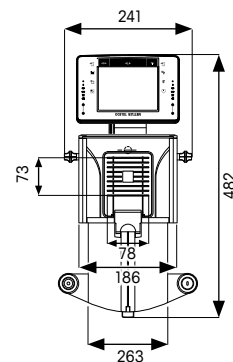
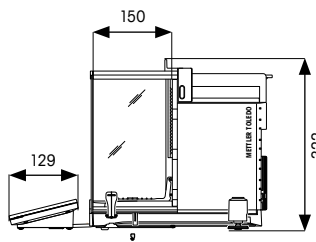

All dimensions are given in mm.

XPE Micro-analytical		XPE26	XPE26DR	XPE56	XPE56DR
Maximum capacity (fine range/full range)		22 g	5.1 / 22 g	52 g	11 / 52 g
Readability	full range	0.001 mg	0.01 mg	0.001 mg	0.01 mg
	fine range		0.002 mg		0.002 mg
Repeatability* (5% load)		0.0007 mg	0.0012 mg	0.0007 mg	0.0012 mg
Settling time		3.5 s	2.5 / 3.5 s	3.5 s	2.5 / 3.5 s
Minimum weight* (1.0%, k=2, 5% load)		0.14 mg	0.24 mg	0.14 mg	0.24 mg
USP minimum weight* (1.0%, k=2, 5% load)		1.4 mg	2.4 mg	1.4 mg	2.4 mg

\* = typical value



<b>XPE Analytical</b>	<b>XPE206DR</b>	<b>XPE105</b>	<b>XPE105DR</b>	<b>XPE205</b>	<b>XPE205DR</b>
Maximum capacity (fine range/full range)	81 / 220 g	120 g	41 / 120 g	220 g	81 / 220 g
Readability	full range fine range	0.01 mg 0.005 mg	0.01 mg	0.1 mg 0.01 mg	0.01 mg 0.01 mg
Repeatability* (5% load)	0.005 mg	0.007 mg	0.007 mg	0.007 mg	0.007 mg
Settling time* (fine range/full range)	2.5 / 3.5 s	2.5 s	1.5 / 2.5 s	2.5 s	1.5 / 2.5 s
Minimum weight* (1.0%, k=2, 5% load)	1.0 mg	1.4 mg	1.4 mg	1.4 mg	1.4 mg
USP minimum weight* (0.1%, k=2, 5% load)	10 mg	14 mg	14 mg	14 mg	14 mg

	<b>XPE204</b>	<b>XPE304</b>	<b>XPE504</b>	<b>XPE504DR</b>
Maximum capacity (fine range/full range)	220 g	320 g	520 g	101 / 520 g
Readability	full range fine range	0.1 mg	0.1 mg	1 mg 0.1 mg
Repeatability* (5% load)	0.04 mg	0.04 mg	0.04 mg	0.04 mg
Settling time* (fine range/full range)	1.5 s	1.5 s	1.5 s	1.5 / 1.5 s
Minimum weight* (1.0%, k=2, 5% load)	8.2 mg	8.2 mg	8.2 mg	8.2 mg
USP minimum weight* (0.1%, k=2, 5% load)	82 mg	82 mg	82 mg	82 mg

\* = typical value

## Features – XPE Micro-analytical and Analytical

<b>Accurate Results</b>	High resolution technology
	StaticDetect
	proFACT Advanced internal adjustment
	Lowest minimum weight
	Internal temperature control
<b>Efficient Operation</b>	Large TFT <sup>Plus</sup> color touchscreen
	ErgoClip ready
	SmartGrid hanging weighing pan
	SmartTrac dosing guide
	Big numbers on display
	Easy cleaning
	Automatic draft shield doors
<b>Quality Assurance</b>	SmartSens for touch-less operation
	StatusLight
	Graphical leveling guide
	TestManager embedded software
	MinWeigh function
	FACT and GWP history
	proFACT Advanced documentation
	Password protection
Admin history	
<b>Seamless Process</b>	User management
	LabX ready
	Calibry ready
	EasyScan™ ready (RFID Pipette)
	SmartSample ready (RFID Titration)**
	Quantos upgrade ready**
	New compact antistatic kit ready

### Embedded Applications

Simple weighing, statistics, formulation, totalization, piece counting, percent weighing, density determination, differential weighing, underfloor weighing, pipette check, titration application and routine testing.

\*\* not valid for XPE Micro-analytical

# Quantos Automated Dosing Highest Accuracy and Safety

**Automated dosing with Quantos powder and liquid dispensing modules enables you to achieve the highest level of accuracy and safety in sample preparation, and can reduce minimum weight by up to 30%.**

When working with valuable or toxic substances, this means only the minimum amount of substance necessary is used. Sample preparation via gravimetric addition of the right amount of solvent to reach the target concentration eliminates variability and out-of-specification errors, and complies with USP 841.

Ideal for:

- Sample and standard preparation
- Routine powder dispensing and bottling
- Capsule and bottle filling
- Formulation and stability testing
- Materials research
- Weighing hazardous compounds

## Smallest minimum weight



Automated dosing and weighing reduces the minimum sample weight of your balance by up to 30%. Nanoparticles, fine powders, granules and heterogeneous mixes are all suitable for dispensing.

## Protects users



Operator exposure to hazardous and toxic substances is minimized by attaching the Quantos dosing head directly to the sample container. The powder is then dispensed directly into the target vial.

## Contamination-free weighing



One powder dosing head is dedicated to one substance or lot number for the duration of its lifetime to avoid cross contamination. Heads are disposed of after use.



Boost productivity with the auto sampler which can dose into up to 30 vials in one fully automated run (powder and liquid dosing).

### Secure processes



The Quantos WorkflowBox, powered by LabX, stores complex pre-configured applications, such as dilutions, which are run directly from the balance. Each application is started with a shortcut on the balance to ensure all users precisely follow the defined SOPs.

### Container flexibility



By simply adjusting the height of the dosing head, Quantos can be used for filling vials, bottles, tubes, capsules, stability pouches, ampules, syringes and more.

## QUANTOS

Perfect Dosing

► [www.mt.com/quantos](http://www.mt.com/quantos)

# Technical Specifications

## Quantos Automated Dosing Systems

**Preparing samples is a labor-intensive task influenced by many factors including the environment and user skill. Automated dosing with Quantos powder and liquid dispensing modules enables you to achieve the highest level of accuracy and safety in sample preparation.**

The Quantos system is modular, depending on your specific dosing needs. Below, typical Quantos systems are depicted.

### QA3 – L system

XPE205  
QL2 Liquid Dosing Module  
QLX45 Dispensing module



The Quantos liquid dosing module and dispensing unit enables extremely accurate gravimetric addition of liquids and solvents. The XPE205 analytical balance can still be used in the usual way.

### QB5 – PL system

XPE206DR  
Q2 Powder Dosing Module  
QL2 Liquid Dosing Module



Both the Quantos powder and liquid dosing modules can be added to the XPE206DR analytical balance to create the perfect setup for accurate standard preparation.

### QB5 – PS system

XPE206DR  
Q2 Powder Dosing Module  
QS30 Auto Sampler



Add the Quantos powder dosing unit and auto sampler to the XPE206DR to allow up to 30 samples to be accurately dispensed in one automated run.

<b>Quantos</b>	<b>XPE56Q</b>	<b>XPE206DR</b>	<b>XPE205</b>	<b>XPE205DR</b>	<b>XPE105</b>
Maximum capacity (fine range/full range)	52 g	81 / 220 g	220 g	81 / 220 g	120 g
Readability	full range fine range	0.001 mg	0.01 mg 0.005 mg	0.1 mg 0.01 mg	0.01 mg
Repeatability* (5% load)	0.0007 mg	0.005 mg	0.007 mg	0.007 mg	0.007 mg
Settling Time*	3.5 s	2.5 / 3.5 s	2.5 s	1.5 / 2.5 s	2.5 s
Minimum weight* (1.0%, k=2, 5% load)	0.14 mg	1.0 mg	1.4 mg	1.4 mg	1.4 mg
USP minimum weight* (0.10%, k=2, 5% load)	1.4 mg	10 mg	14 mg	14 mg	14 mg
Autom, minimum weight* (1.0%, k=2, 5% load)	0.4 mg	0.7 mg	1 mg	1 mg	1 mg
Automated USP minimum weight* (0.10%, k=2, 5% load)	4 mg	7 mg	10 mg	10 mg	10 mg
Lowest concentration* (in combination with QLB) according automated USP minimum weight	0.15 mg / g	0.07 mg / g	0.1 mg / g	0.1 mg / g	0.2 mg / g

#### Compatibility

<b>Q2 Powder Dosing Unit</b>	yes	yes	yes	yes	yes
<b>QL2 Liquid Dosing Unit</b>	yes	yes	yes	yes	yes
<b>QLL1000 (bottle and volume up to 3 per QL2)</b>	yes	yes	yes	yes	yes
<b>QLX45</b>	no	no	(required when Q2 not incl.)		
<b>QS30 Auto Sampler</b>	no	yes	yes	yes	yes

\* = typical value

	<b>XPE105DR</b>	<b>XPE204</b>	<b>XPE304</b>	<b>XPE504</b>	<b>XPE504DR</b>
Maximum capacity (fine range/full range)	41 / 120 g	220 g	320 g	520 g	101 / 520 g
Readability	full range fine range	0.1 mg 0.01 mg	0.1 mg	0.1 mg	0.1 mg 1 mg
Repeatability* (5% load)	0.007 mg	0.04 mg	0.04 mg	0.04 mg	0.04 mg
Settling time*	1.5 / 2.5 s	1.5 s	1.5 s	1.5 s	1.5 / 1.5 s
Minimum weight* (1.0%, k=2, 5% load)	1.4 mg	8.2 mg	8.2 mg	8.2 mg	8.2 mg
USP Minimum weight* (0.10%, k=2, 5% load)	14 mg	82 mg	82 mg	82 mg	82 mg
Automated minimum weight* (1.0%, k=2, 5% load)	1 mg	8.2 mg	8.2 mg	8.2 mg	8.2 mg
Automated USP minimum weight* (0.10%, k=2, 5% load)	10 mg	82 mg	82 mg	82 mg	82 mg
Lowest concentration (in combination with QLB) according automated USP minimum weight	0.2 mg / g	0.58 mg / g	0.29 mg / g	0.15 mg / g	0.15 mg / g

#### Compatibility

<b>Q2 Powder Dosing Unit</b>	yes	yes	yes	yes	yes
<b>QL2 Liquid Dosing Unit</b>	yes	yes	yes	yes	yes
<b>QLL1000 (bottle and volume up to 3 per QL2)</b>	yes	yes	yes	yes	yes
<b>QLX45 (required when Q2 not incl.)</b>	(required when Q2 not incl.)				

\* = typical value

### QX7 system



This top-of-the-range fully automated Quantos system provides the most precise concentrations with minimum error and maximum repeatability.

# XPE Precision Balances

## Small Samples up to 5 kg

**XPE precision balances offer high readability and excellent repeatability for weighing small samples all the way up to 5 kg. With the smallest footprint of all our precision balances, touch-less operation and fast, efficient weighing processes, these balances are a practical addition to any laboratory.**

With 1 mg and 0.1 mg readability, the flexible draft shield ensures fast settling times whilst allowing easy access to the weighing chamber for handling large tare containers and weighing-in samples. The draft shield dismantles in seconds and goes in the dishwasher for easy cleaning.

### Compact draft shield



The compact draft shield allows easy access from all sides for handling large items and to make dosing easy. When open, the doors do not extend beyond the rear of balance so you don't waste valuable bench space.

### Touch-less operation



The SmartSens infrared sensors built into the terminal enable you to perform selected balance operations at the wave of a hand e.g. weigh, tare, or even send results to the printer. Weighing processes are more ergonomic and cross contamination is avoided.

### Ergonomic weighing



The MagicCube™ draft shield accessory has no lid making it easy to use extra-large containers on your 1 mg balance. Just open the side for easy access and weigh-in directly from the top. The weighing pan is protected from air currents so you get faster results.



**High readability – economical on space**

With maximum capacity up to 410 g, our 0.1 mg readability XPE precision balances give you high performance on a small footprint.

► [www.mt.com/xpe-precision](http://www.mt.com/xpe-precision)

# XPE Precision Balances

## Samples up to 10 kg

**Thanks to the innovative SmartPan weighing pan, small platform XPE precision balances demonstrate up to two times faster stabilization times with repeatability improved up to two-fold when compared to a traditional weighing pan.**

It's now possible to weigh-in with 5 mg readability without the need for a draft shield. SmartPan enables all users to quickly achieve stable weight values and better repeatability, even within the turbulent environment of a fume cupboard. In addition, thanks to unique quality management features such as StatusLight, the requirements of highly regulated environments are fully supported.

### Ergonomic operation



Avoid stresses and strains from working for long periods in front of the balance by placing your terminal on a stand and adjusting the tilt to suit your height; the display is easier to read and good posture is maintained. Touch-less operation with SmartSens makes weighing even more comfortable.

### Easy cleaning



SmartPan dismantles easily and any spilled substances remain in the tray underneath for safe disposal and easy cleaning. All parts are dishwasher safe. Smooth surfaces and rounded edges make the whole balance easy to clean.

### Robust performance



With IP54 in-use, the weighing cell is protected against dust and splashing liquids. Combined with a full metal housing, which protects against damage from harsh chemicals, you can be assured of a long balance lifetime.





The graph below indicates the dramatic improvement in settling time and repeatability when using SmartPan under both normal and harsh weighing conditions. Tests made using an XPE6003SD5 (6100 g maximum capacity and 5 mg readability).

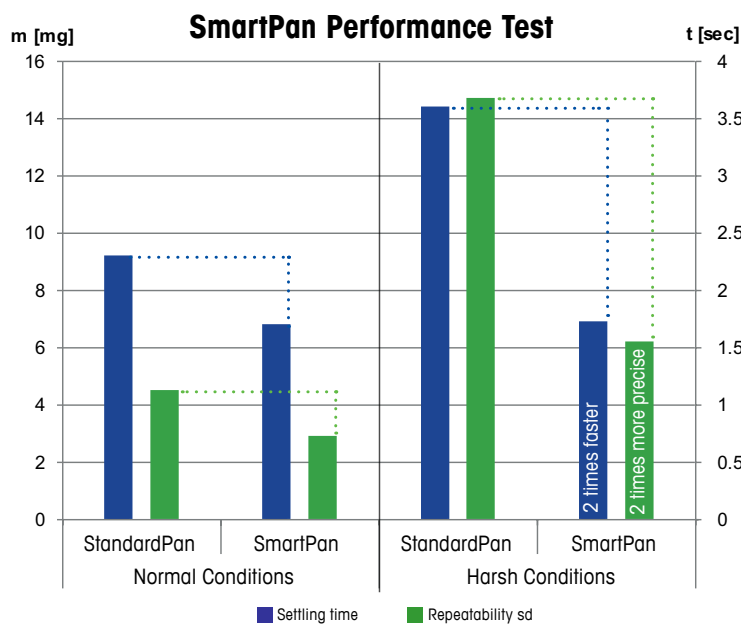

**Prof. Peter Ryser,**  
**Head of Microtechnology Institute,**  
**Ecole Polytechnique Fédérale de Lausanne (EPFL)**

The independent white paper from Prof. Ryser details the improvement in accuracy and stability in XPE precision balances thanks to the unique design of the new weighing pan.

► [www.mt.com/xpe-precision](http://www.mt.com/xpe-precision)

# XPE Precision Balances

## Large Samples up to 64 kg

**Large platform XPE precision balances provide the best weighing performance for high capacity loads and offer a level of security suitable for highly regulated environments.**

The large weighing platform is ideally suited to applications involving large containers, large sample sizes or when many ingredients need to be added to the same container e.g. formulation and buffer preparation. With 0.1 g readability up to 64 kg and 0.01 g readability up to 20 kg, small sample quantities can be weighed into the same container. Considerable cost savings are made by eliminating the need to have a second balance, and processes are more efficient too. The robust design, including IP54 in-use protection, means these balances are perfect for use in production environments.

### Extremely durable



With the built-in overload protection, which ensures the weighing cell is fully safeguarded against excessive loads, these robust balances can withstand even the toughest of working environments.

### Optimized processes



Connect a barcode reader for easy sample identification. Send results to a wireless printer outside your immediate working area. Connectivity options enable you to optimize working processes to be more ergonomic and efficient (RS232, Ethernet, Bluetooth, etc.).

### Chemical resistant



The high quality AISI 316L stainless steel weighing pan and the solid metal housing protect the balance against damage from dirt and chemicals. Disposable covers protect the display and prevent cross contamination.



### **Weighing flexibility**

The two new models feature 10 mg readability enabling both small and large quantities of formulation ingredients to be weighed directly into the same container. SmartPan is accessed by lifting off the center pan and provides fast and stable results even when weighing in harsh conditions.

► [www.mt.com/xpe-precision](http://www.mt.com/xpe-precision)

# Technical Specifications

## Precision Balances

**XPE Precision S-Platform**  
Readability 0.1 mg

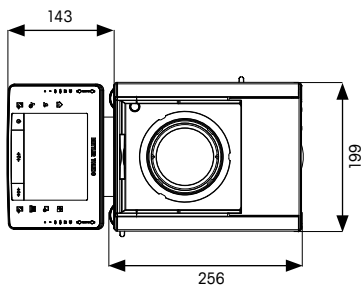
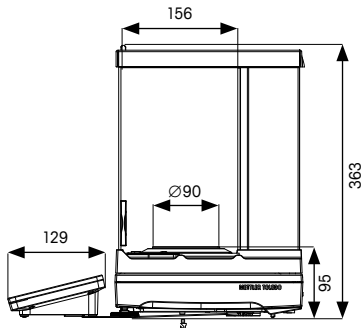

**XPE Precision S-Platform**  
Readability 1 mg

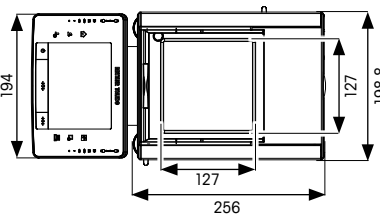
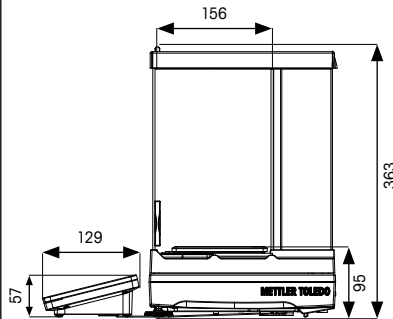

**XPE Precision S-Platform**  
Readability 0.01 g – 0.005 g

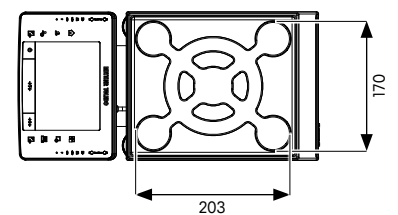
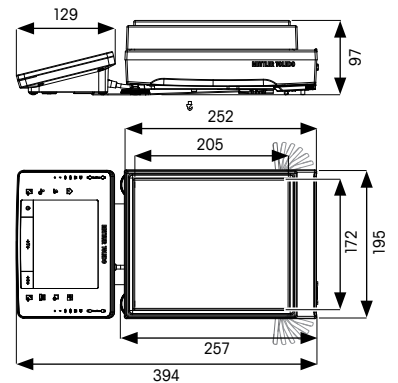

All dimensions are given in mm.

**XPE Precision S-Platform  
Readability 0.1 g – 1 g**

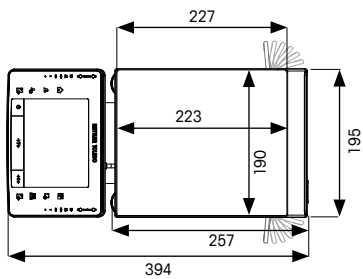
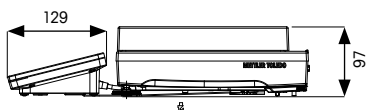

**XPE Precision L-Platform  
Readability 0.01 g**

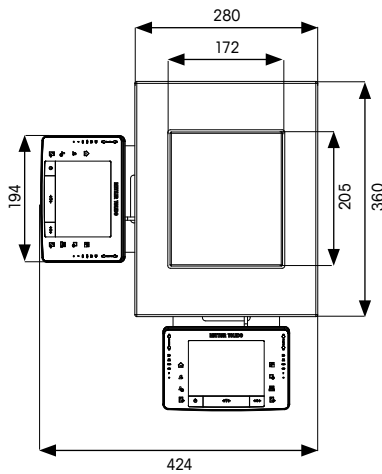
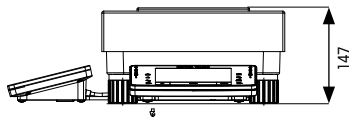

**XPE Precision L-Platform  
Readability 0.1 g – 1 g**

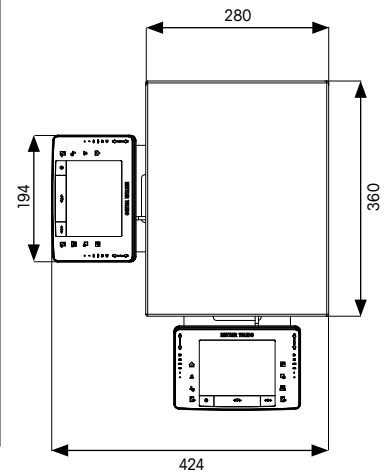
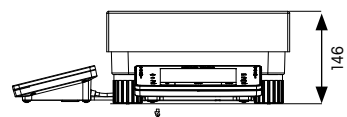

<b>XPE Precision Balances</b>	<b>XPE204S</b>	<b>XPE404S</b>	<b>XPE303S</b>	<b>XPE603SDR</b>	<b>XPE603S</b>
Maximum capacity (fine range/full range)	210 g	410 g	310 g	120 / 610 g	610 g
Readability	0.1 mg	0.1 mg	1 mg	10 mg 1 mg	1 mg
Repeatability*	0.12 mg	0.06 mg	0.5 mg	0.8 mg	0.5 mg
Settling time*	2 s	2 s	1.5 s	1.5 s	1.5 s
Minimum weight* (1.0%, k=2, 5% load)	24 mg	12 mg	100 mg	160 mg	100 mg
USP minimum weight* (0.10%, k=2, 5% load)	240 mg	120 mg	1 g	1.6 g	1 g

\* = typical value

	<b>XPE1203S</b>	<b>XPE3003S</b>	<b>XPE5003S</b>	<b>XPE3003SD5</b>	<b>XPE6003SD5</b>
Maximum capacity	1210 g	3100 g	5100 g	3100 g	6100 g
Readability	1 mg	1 mg	1 mg	5 mg	5 mg
Repeatability*	0.4 mg	0.6 mg	1 mg	3 mg	3 mg
Settling time*	1.5 s	2 s	2 s	2 s	2 s
Minimum weight* (1.0%, k=2, 5% load)	82 mg	120 mg	200 mg	600 mg	600 mg
USP minimum weight* (0.10%, k=2, 5% load)	820 mg	1200 mg	2 g	6 g	6 g

\* = typical value

	<b>XPE1202S</b>	<b>XPE2002S</b>	<b>XPE4002S</b>	<b>XPE6002SDR</b>	<b>XPE6002S</b>
Maximum Capacity (fine range/full range)	1210 g	2.1 kg	4.1 kg	1.2 / 6.1 kg	6.1 kg
Readability	10 mg	10 mg	10 mg	100 mg 10 mg	10 mg
Repeatability*	4 mg	4 mg	4 mg	5 mg	4 mg
Settling time*	1.2 s	1.2 s	1.2 s	1.2 s	1.2 s
Minimum weight* (1.0%, k=2, 5% load)	820 mg	820 mg	820 mg	1 g	820 mg
USP minimum weight* (0.10%, k=2, 5% load)	8.2 g	8.2 g	8.2 g	10 g	8.2 g

\* = typical value

	<b>XPE8002S</b>	<b>XPE10002S</b>	<b>XPE15002L</b>	<b>XPE20002L-DR</b>	<b>XPE4001S</b>
Maximum capacity (fine range/full range)	8.1 kg	10.1 kg	15100 g	4.2 / 20.1 kg	4.1 kg
Readability	10 mg	10 mg	10 mg	100 mg 10 mg	100 mg
Repeatability*	4 mg	4 mg	10 mg	20 mg	40 mg
Settling time*	1.5 s	1.5 s	1.5 s	1.5 s	0.8 s
Minimum weight* (1.0%, k=2, 5% load)	820 mg	820 mg	2 g	4 g	8.2 g
USP minimum weight* (0.10%, k=2, 5% load)	8.2 g	8.2 g	20 g	40 g	82 g

\* = typical value

	<b>XPE6001S</b>	<b>XPE8001S</b>	<b>XPE10001S</b>	<b>XPE10001L</b>	<b>XPE16001L</b>
Maximum capacity	6.1 kg	8.1 kg	10.1 kg	10.1 kg	16.1 kg
Readability	100 mg	100 mg	100 mg	100 mg	100 mg
Repeatability*	40 mg	40 mg	40 mg	60 mg	40 mg
Settling time*	0.8 s	1 s	1 s	1 s	1.5 s
Minimum weight* (1.0%, k=2, 5% load)	8.2 g	8.2 g	8.2 g	12 g	8.2 g
USP minimum weight* (0.10%, k=2, 5% load)	82 g	82 g	82 g	120 g	82 g

\* = typical value

<b>XPE Precision</b>	<b>XPE32001L</b>	<b>XPE64001L</b>	<b>XPE32000L</b>	<b>XPE64000L</b>
Maximum capacity	32.1 kg	64.1 kg	32.1 kg	64.1 kg
Readability	100 mg	100 mg	1 g	1 g
Repeatability*	40 mg	40 mg	0.4 g	0.4 g
Settling time*	1.5 s	1.8 s	1.2 s	1.5 s
Minimum weight* (1.0%, k=2, 5% load)	8.2 g	8.2 g	82 g	82 g
USP minimum weight* (0.10%, k=2, 5% load)	82 g	82 g	820 g	820 g

\* = typical value

## Features – XPE Precision S and L Platforms

<b>Accurate Results</b>	High resolution technology
	proFACT Advanced (internal adjustment)
	Lowest minimum weight
<b>Efficient Operation</b>	Large TFT <sup>Plus</sup> color touchscreen
	SmartPan**
	SmartTrac dosing guide
	Big numbers on display
<b>Quality Assurance</b>	Easy cleaning
	SmartSens for touch-less operation
	StatusLight
	Graphical leveling guide
	TestManager embedded software
	MinWeigh Function
	FACT and GWP history
	proFACT Advanced documentation
	Password protection
Admin history	
<b>Seamless Process</b>	User management
	LabX ready
	Calibry ready

\*\* = available only for 5 and 10 mg models

### Embedded Applications

Simple weighing, statistics, formulation, totalization, piece counting, percent weighing, density determination, differential weighing, underfloor weighing, pipette check, titration application and routine testing.

# METTLER TOLEDO Services

## Ensure Consistently Reliable Results

From evaluating your needs to select the right balance, through to daily routine operation in your lab, the METTLER TOLEDO Sales & Service Team can accompany you every step of the way. Our expertise means you can enjoy excellent performance, maximum uptime and full compliance with the norms and standards relevant to your industry.



### Good Weighing Practice™

METTLER TOLEDO developed GWP® (Good Weighing Practice™) as a standardized scientific methodology for the secure selection, operation and calibration of weighing equipment. GWP® is applicable to all weighing equipment from any manufacturer.

### Evaluation and selection



Our GWP® Recommendation service helps you select the right balance according to your specific process and quality requirements. Documentary evidence is provided to show that the selected balance meets metrological, environmental and regulatory requirements.





Global Reach – Local Presence! A team of 5,000 specialists represent METTLER TOLEDO Sales and Service in more than 140 countries worldwide.

► [www.mt.com/service](http://www.mt.com/service)

### Installation



We document the installation and qualification of your balance in accordance with the relevant industry regulations. Operator training right after installation leads to improved productivity.

### Calibration



Balance calibration is at the core of accurate weighing results. Each calibration certificate declares the balance's minimum weight and measurement uncertainty – essential information for reliable weighing processes.

### Routine operation



GWP® Verification provides clear guidance for performance verification of your balance to save you time and money. Included is an optimal routine testing and calibration schedule, specifications of the required test weights, and the ideal maintenance plan.

# Ensure Worry-free Weighing with Smart Accessories and Options

**METTLER TOLEDO balances can be customized with accessories and peripheral devices to meet the needs of virtually any application. Our carefully designed accessories make your work easier, reduce fatigue and increase accuracy and productivity.**

Small details. Big difference. View our range of over 200 accessories online.

## Reliable sample transfer



SmartPrep™ single-use, antistatic funnels enable safe and fast weighing-in of powders. Simply weigh, transfer and rinse. Fits nearly any standard 5 – 250 mL flask.

## Protect results from static



The compact point electrode removes electrostatic charge on samples and containers. Free-standing units are also available.

## Safely use magnetic stirrers



The Magnetic Protection Shield (MPS) weighing pan blocks interference from magnetic samples and stir bars to ensure accurate results.

## Comfortable operation



Place your terminal on a stand which is quickly mounted at the back of your balance. The display is easier to read and good posture is maintained.

## Easy documentation



The P-50 printers generate fast, high quality printouts on paper, self-adhesive labels and continuous self-adhesive paper (including barcodes).

## Protect your balance



Disposable terminal covers protect your balance and help avoid cross-contamination. When not in use, a dust cover shields your balance against soiling.

► [www.mt.com/lab-accessories](http://www.mt.com/lab-accessories)



## LabX Laboratory Software

### Power the Bench

LabX brings power to your laboratory bench by providing full user guidance on the instrument touchscreen, handling all data automatically, and ensuring process security on multiple instruments – all with one software.



### Comfortable, worry-free weighing processes, thanks to:

- Full workflow flexibility
- Shortcuts on the instrument display to start processes
- Step-by-step SOP user guidance on the balance
- Automatic calculations and documentation
- Customized reports and labels printed automatically
- All data stored centrally
- Know-one-know-all interface (also compatible with titrators, density meters, refractometers and melting point instruments)



LabX comes with 3 built-in One Click™ workflows to get you off to a quick start. Watch our video to see how easy standard preparation is with LabX.

► [www.mt.com/one-click-weighing](http://www.mt.com/one-click-weighing)

# Benefit From Our Weighing Expertise

With decades of experience in laboratory weighing, METTLER TOLEDO can offer you a wide range of online learning resources. Take advantage of our expertise to enhance your weighing know-how and make the most of your balance. Check out the documentation on our internet pages for a range of relevant materials.



## Videos

In an easy learning format, our videos demonstrate the use of our balances and inform you about our weighing solutions. For example:

- Antistatic Solutions
- Easy Cleaning
- ErgoClips

▶ [www.youtube.com/mtlaboratory](http://www.youtube.com/mtlaboratory)



## White Papers

Our scientific white papers contain a wealth of information on a range of different topics such as:

- GWP – Science Based Weighing
- Balance Safety Features
- Antistatic Technology
- Data Integrity

▶ [www.mt.com/balances](http://www.mt.com/balances)



## On-demand Webinars/E-Learning

Learn directly from our weighing experts and guest speakers. It's easy to register.

For starters, we recommend:

- Minimizing Out-of-Specification Errors
- Good Weighing Practice

▶ [www.mt.com/webinars](http://www.mt.com/webinars)

▶ [www.mt.com/lab-elearning](http://www.mt.com/lab-elearning)

[www.mt.com/balances](http://www.mt.com/balances)

For more information

## Mettler-Toledo AG

Im Langacher 44  
8606 Greifensee, Switzerland  
Tel. +41-44-944 22 11  
Fax +41-44-944 30 60

Subject to technical changes  
© 07/2014 Mettler-Toledo AG  
Printed in Switzerland 30208820  
Global MarCom Switzerland

